

# SCANNING PROBE MICROSCOPE CONTROL SYSTEM

## Unisurface $\alpha$



Unisurface  $\alpha$ , the state of the art SPM Data Acquisition System, has been improved as future equipment based on UNISOKU's decades-long experience of development and sales. Usability and functional performance are highly upgraded by full digital control.

### Feature

- Precise measurement sequence by full digital control
- Enhancement of maintenance and support system by modular architecture
- Superior "High-Stability" and "Low-Noise" electronics
- "Easy-to-Use" graphical user interface

### Unisurface $\alpha$ Standard Component

#### ► CONSTRUCTION

1.SPM CONTROLLER (Built-in Standard Module)	USC-CIRT 1
	W448.4 x H174.4 x D411(mm)
	USC-INP x 1
	USC-SCAN x 1
	USC-STG x 1
	USC-HVD x 1 USC-DRV x 1
2.POWER	USC-POWD 1
	W448.4 x H174.4 x D411(mm)
3.CPU	USC-CPU 1
	W448.4 x H174.4 x D411(mm)
4.DISPLAY	1 17inch and above

\*Enable to opt for the rack which is applied to 19inch standard, EIA standard 4U.

## DATA

Constant Current Image of Si(111) -7x7 Surface

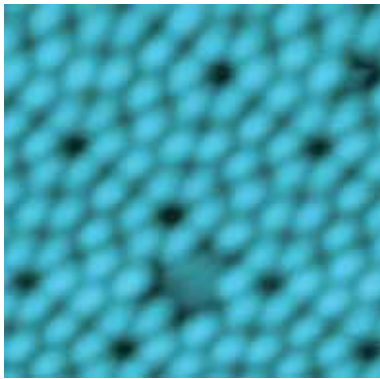

Sample Bias  $V_s = 1.20$  V  
Tunnel Current  $I_t = 0.40$   
~3min./image

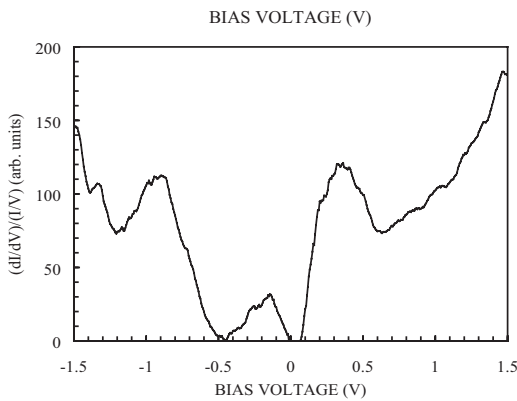

## BLOCK DIAGRAM

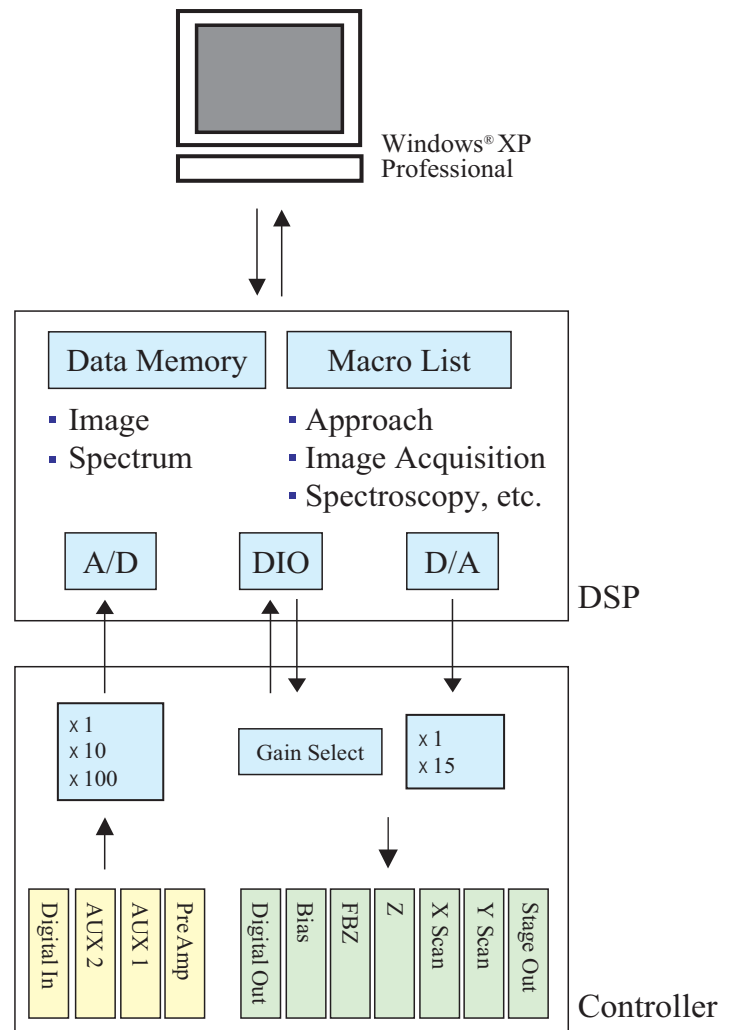

### Specification

Acknowledge that the composition and the specification, etc. might be changed without a previous notice beforehand.

Input Channel	Analog	4ch (Option : Additionnal 4ch)	
	Digital	Optional : 16bit 1ch	
Feedback	Digital I control		
Feedback bandwidth	10kHz		
Feedbackfunction	Linear, Log, fifth polynomial system		
Feedback range	+/- 150V		+/- 10V
	Option : +/- 200V		
Z direction resolution (Input/Output)	16bit/16bit		
Highest resolution in Z direction	0.31mV		
Current minimum detection	0.8pA		
Approach circuit control method	Inertial drive method (Option:Stepping motor method)		
Scan range	+/- 150V, +/- 10V		
Bias range	+/- 10V, +/- 1V, +/- 0.1V (Option : the user-specified)		
Manual retract	○		
Stage drive circuit	External (USC-MST) Built-in extention board (Max.2 axis)		
OS	Windows XP Professional		
Display for PC	PC Display 1 (17inch and over)		
Maximum pixels	1024 x 1024		
Shape of scan area	Square, Rectangle		
Rotation of scan size	360 celsius degree		
Real-time image display	10 images		
Scan direction	Forward/Backward		
External trigger	Input	○	
	Output	○	

Spectroscopy	I-V, I-Z, etc.
Measurement point	Specified point, Line, Grid
Other function	Multiple bias, CITS, Lithography, FFT-PowerSpec.
Image data format	Unisoku original
Spectorocopy data format	ASCII
Power-supply voltage	100VAC (50/60Hz) : Optional other voltage
Color monitor display	Display type : 17" LCD Max resolution : 1280 x 1024 pixels

### Option

Original rack (EIA standard)	1	
Stage drive (electronics)	External circuit (USC-MST) or Built-in unit board	
AFM measurement	External AFM control circuit (SPM-AFM) or AFM control crcuit on market	
Lock-in amplifier for modulation measurement	External circuit (Lock-in amplifier for modulation measurementU100-1025P)	
KFM measurement	External circuit (unit for KFM meassurement UKFM-100)	
Preamp (optional)	10 <sup>7</sup> Multiple Amplifier	
	10 <sup>8</sup> Multiple Amplifier	
	10 <sup>9</sup> Multiple Amplifier	
Current range	10 <sup>7</sup> Multiple Amplifier	50pA ⇔ 1μm
	10 <sup>8</sup> Multiple Amplifier	5pA ⇔ 10nA
	10 <sup>9</sup> Multiple Amplifier	1pA ⇔ 10nA

Unisoku Co., Ltd.

2-4-3, Kasugano Hirakata, Osaka 573-0131, Japan

TEL 81-72-(858)-6456 FAX 81-72-(859)-5655

E-Mail info@unisoku.co.jp http://www.unisoku.co.jp